

Steven Logghe

Mobility Data Space on Traffic Counts

The end-user perspective

Dr. Steven Logghe

DIGITAAL
VLAANDEREN



Vlaamse
overheid



- Data Space -

AS-IS

Veel verschillende manieren (en standaarden) om data uit te wisselen, zowel langs de publishers kant als langs de consumers kant.

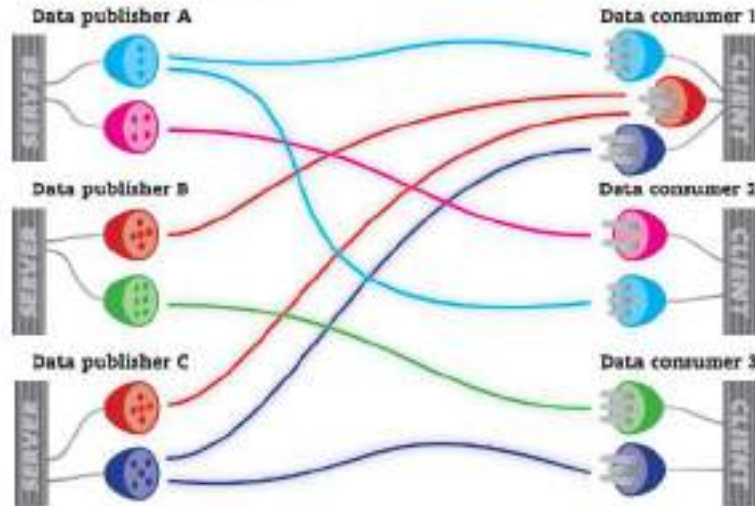

TO-BE

Standaardisatie: publishers publiceren via dezelfde standaard, waardoor consumers met dezelfde "aansluiting" overal data kunnen halen.

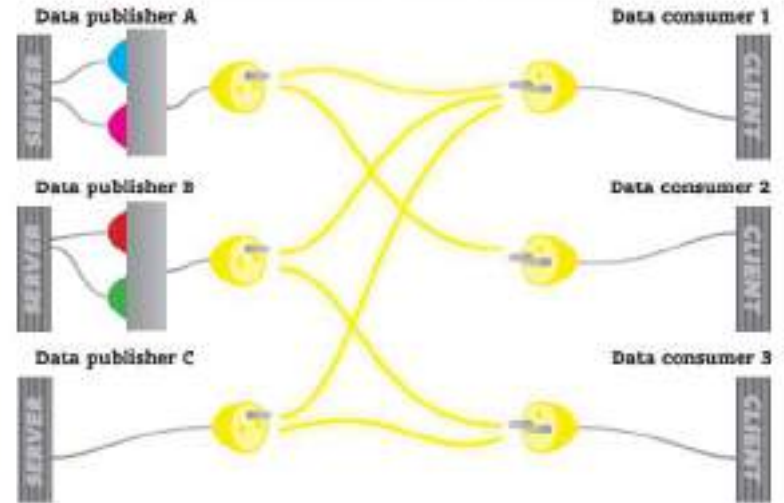

Current workflow for a data user

- I want to make a **mobility analysis based on two data sets** of traffic measurements



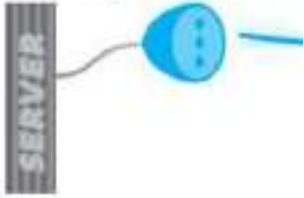

Current Workflow - Geomobility

- Traffic data from the city of Bruges is on the Geomobility platform.
- Only after subscription, you can see the data availability
- You can consult, query and download it.
- You need an API to query and consult different measurement locations



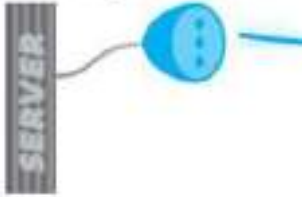

Current workflow – Geomobility

- Geomobility API:
- Dataset as JSON file
- Data has own classification (P/C = personal vehicle,...), it is not standardized
- The data has no semantic, it is not without manual of Geomobility.



```
"data": [ { "_id":  
"64c3e03da4d94b14206ebca9", "type":  
"standart", "origin": "A", "destination": "B",  
"classification": "P/C", "timestamp": "2023-  
05-07T22:30:00.000Z", "count": 1, "poild":  
"5ed752d5-a754-415c-97a1-0ca27cff1a81",  
"surveyId": "903e2e28-919e-4fcf-8a68-  
8a46bc3c9b94" }, { "_id":  
"64c3e03da4d94b14206ebcaa", "type":  
"standart", "origin": "B", "destination": "A",  
"classification": "P/C", "timestamp": "2023-  
05-07T22:30:00.000Z", "count": 1, "poild":  
"5ed752d5-a754-415c-97a1-0ca27cff1a81",  
"surveyId": "903e2e28-919e-4fcf-8a68-  
8a46bc3c9b94" }
```

Data publisher B

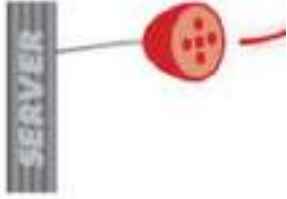

Current workflow: Telraam



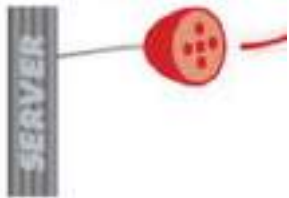

Current Workflow – Telraam

- Without paying account, you can only consult the data, not download the data.
- You can only query data for individual locations.
- You can take a subscription to the API:
- Also here, own data protocol, no standardization
- Also semantic is missing ~~no integration without~~ the Telraam manual.



Data subscription €15 / month
Includes the 23 road user classes, 15 minute data resolution, more tools, and better reports

Q: **How often does your equipment is being replaced?**
Consider the [Telraam](#) interval. This includes a Telraam sensor for all devices, and a set of 15 new 500gpm cables.

Basic data Free for personal use only
Limited to 1000 reads per week per user

```

"properties": { "segment_id": 24948,
"last_data_package": "2023-09-14
08:31:32.782600+00:00", "timezone":
"Europe/Brussels", "date": "2023-09-14
07:00:00+00:00", "period": "hourly", "uptime":
0.7741666666666667, "heavy": 0.0, "car": 0.0, "bike":
0.0, "pedestrian": 0.0, "v85": "" } }, { "type":
"Feature", "geometry": { "type": "MultiLineString",
"coordinates": [ [ [ 4.48769540323306,
51.2992002546036 ], [ 4.48770315069313,
51.2992892351387 ], [ 4.48771466796467,
51.2994215239229 ], [ 4.48763698906074,
51.2996019870262 ], [ 4.48719986341616,
51.3006174845592 ] ] ] },

```

Current workflow: data integration

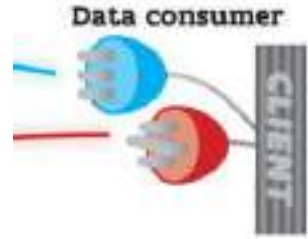

- To make an analysis, you need to integrate both data sets

```
"data": [ { "_id": "64c3e03da4d94b14206ebca9", "type": "standart", "origin": "A", "destination": "B", "classification": "P/C", "timestamp": "2023-05-07T22:30:00.000Z", "count": 1, "poild": "5ed752d5-a754-415c-97a1-0ca27cff1a81", "surveyId": "903e2e28-919e-4fcf-8a68-8a46bc3c9b94" }, { "_id": "64c3e03da4d94b14206ebcaa", "type": "standart", "origin": "B", "destination": "A", "classification": "P/C", "timestamp": "2023-05-07T22:30:00.000Z", "count": 1, "poild": "5ed752d5-a754-415c-97a1-0ca27cff1a81", "surveyId": "903e2e28-919e-4fcf-8a68-8a46bc3c9b94" }
```



```
"properties": { "segment_id": 24948, "last_data_package": "2023-09-14 08:31:32.782600+00:00", "timezone": "Europe/Brussels", "date": "2023-09-14 07:00:00+00:00", "period": "hourly", "uptime": 0.7741666666666667, "heavy": 0.0, "car": 0.0, "bike": 0.0, "pedestrian": 0.0, "v85": "" }, { "type": "Feature", "geometry": { "type": "MultiLineString", "coordinates": [ [ [ 4.48769540323306, 51.2992002546036 ], [ 4.48770315069313, 51.2992892351387 ], [ 4.48771466796467, 51.2994215239229 ], [ 4.48763698906074, 51.2996019870262 ], [ 4.48719986341616, 51.3006174845592 ] ] ] },
```



- You first have an **expensive IT integration job**:
- Set-up a database with a new data base layout
- Technical integration of API's
- Convert the data feeds to your data base layout
- Give an interface on your data base to the traffic analyst
- After this, you can finally start your mobility analysis

Data Space Traffic Measurements

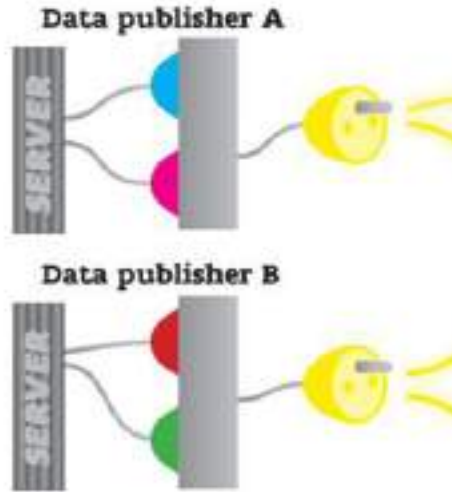

- We developed a common standard OSLO Traffic measurements
- We have building blocks with a standardized LDES interface
- Both GeoMobility and Telraam onboarded on the data space and have now OSLO / LDES Traffic measurements:
 - <https://brugge-ldes.geomobility.eu>
 - <https://telraam-api.net/lDES/observations>
- The data space has a working community to further expand it

- There are building blocks to easily consume the data
- You can easily plug and play with linked data databases
- We build a demonstrator to exploit the linked data: chatgpt can understand it!

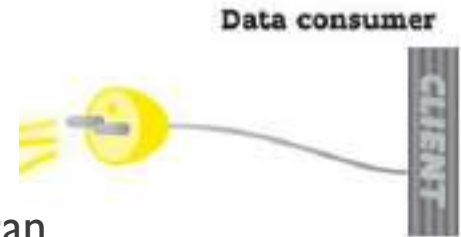

The application runs in a browser.

Demonstrator

Site: een vraag...

Go!

Clear



Demonstrator

You can consult the data in human language

Show me all observations with bikes between 8 and 12 in the morning

Go!

Clear

Show me all observations with bikes between 8 and 12 in the morning



Demonstrator

The visualisation is updated automatically

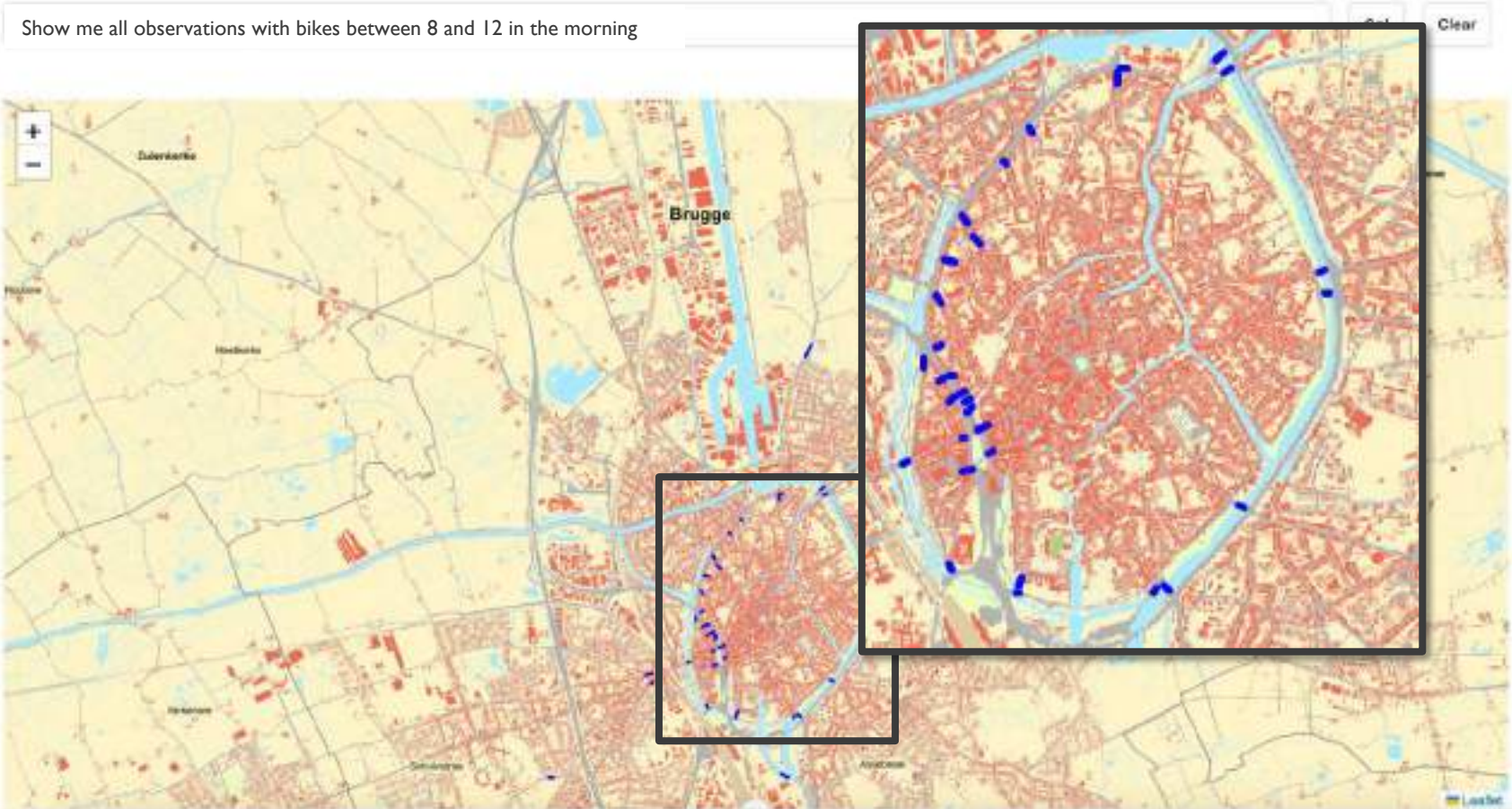

By clicking, the requested data is visualised

Demonstration

Show me all observations with bikes between 8 and 12 in the morning

Go!

Clear

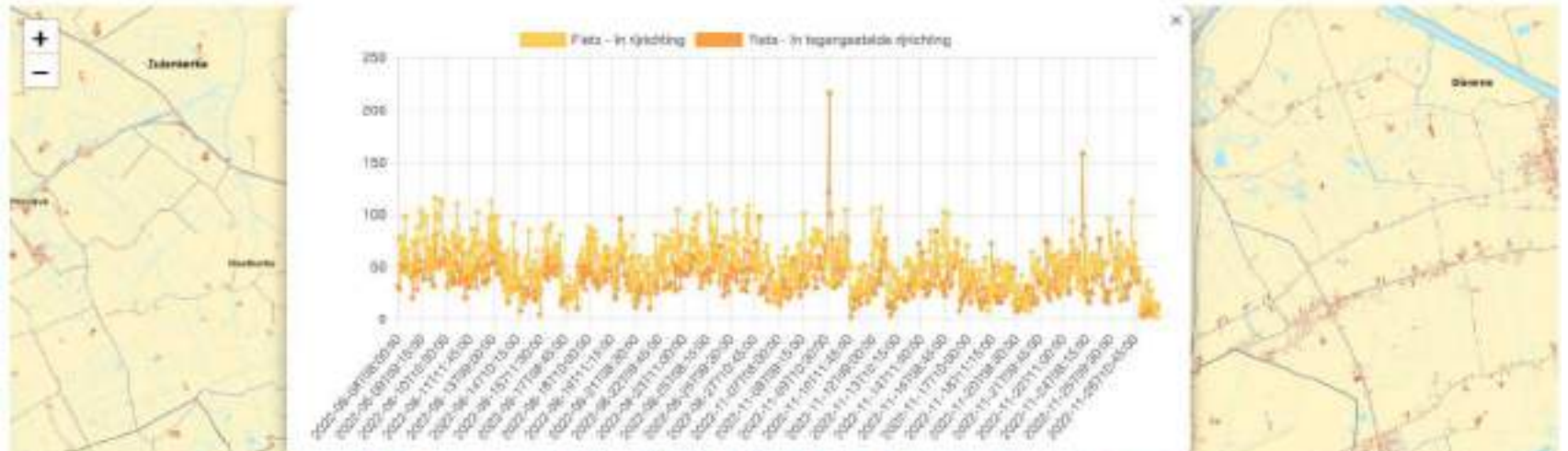

This is a counting point of Geomobility

Demonstrator

Show me all observations with bikes between 8 and 12 in the morning

Go!

Clear



This is a counting point of Telraam

Demonstrator

You can query over data sets, in a creative manner.
Telraam contains worldwide data

Show me the 100 observations with the largest number of cars

Go!

Clear

Show me the 100 observations with the largest number of cars

Demonstrator

Different properties can be combined in one query.

Show me all observations with cyclists, where at least 50 cars pass by

Show me all observations with cyclists, where at least 50 cars pass by

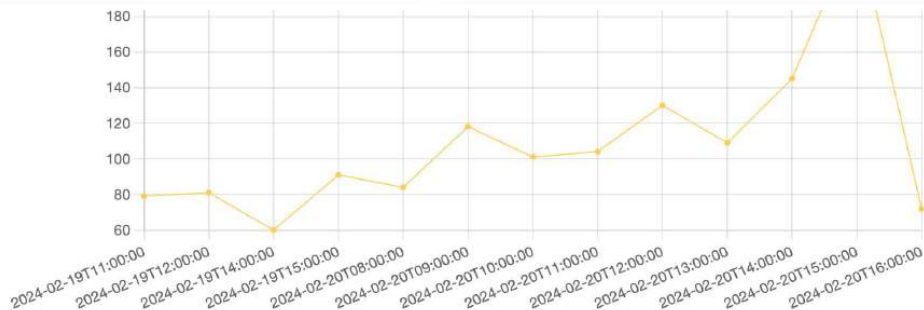

Data Space Traffic Measurements

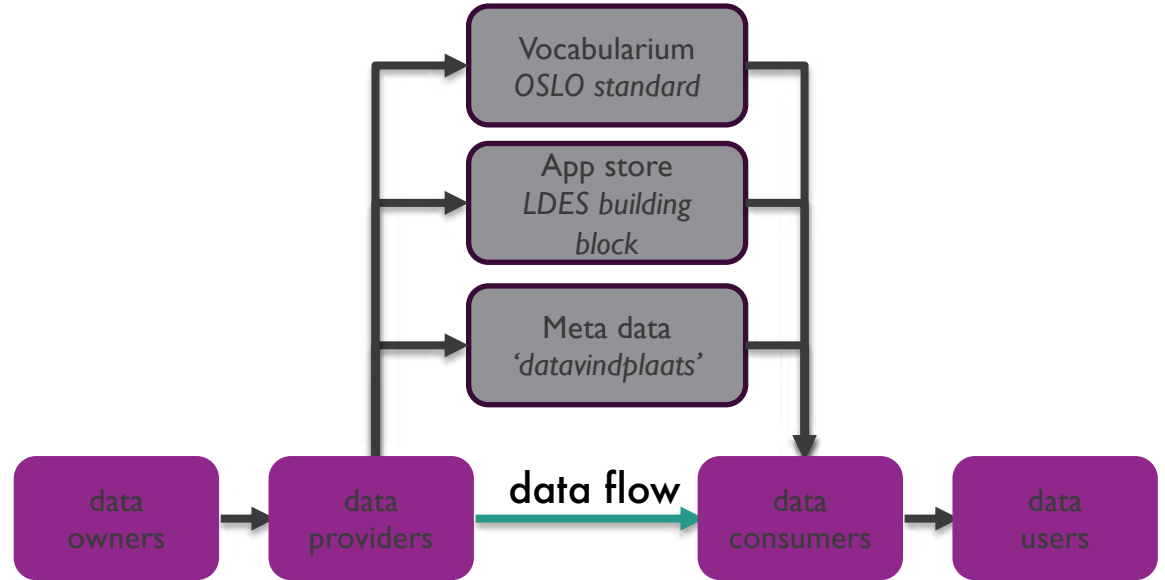

A minimal viable data space:

- Open data
 - No control plane
- => Ecosystem leads to additional onboardings, new consumers coming up!
=> Bottom up during a project => in search for the governance authority

The impact for a user of a Data Space

- How is this enabled?
 - A **metadata catalogue** makes the different datasources findable
 - **Interfaces** : LDES as standard gives a clear interface, building blocks leads to easy set-up
 - **Standards**: OSLO model gives understandable data, for humans and for large language AI
 - Data interoperability lowers the integration costs for new data streams to zero.
 - Chances to easily expand to new data sources
- Data Spaces are the final step within “data interoperability”
⇒ **No more burden for the end users on technical data aspects!**



Contact us:

Steven Logghe

0032 473895257

vsds@vlaanderen.be

<https://www.vlaanderen.be/>

[vlaamse-smart-data-space-portaal](#)